



Armstrong® Steam Distribution Manifold (MSD/SMSD)

Steam Trapping and
Steam Tracing Equipment

As Steam Distribution Assemblies (MSD/SMSD), the manifolds place all steam supply valves in one location. Standardizing components and centralizing their location simplifies installation while providing cost savings. You also save because routine maintenance is faster. Insulation can also be provided...and can be a major savings in most installations.

Cost Savings

- Reduced design specification costs
- Prefabrication vs. field assembly for easy installation
- Reduced shipping and field handling costs
- Lower long-term maintenance and operating costs
- 3-year guarantee

Design Flexibility

- Dimensional consistency
- Space savings
- Insulation package available
- SMSD may also be used on systems utilizing glycol, Dowtherm and other heat transfer liquids.

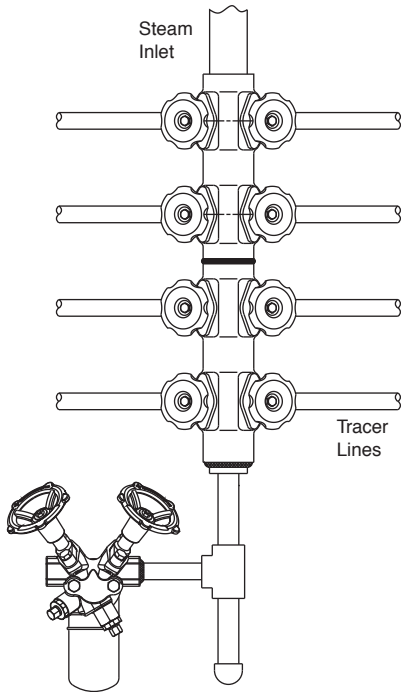

Typical SMSD steam distribution application

(shown with optional nipples and TVS 4000 Trap Valve Station with 2000 Series Inverted Bucket Trap.)

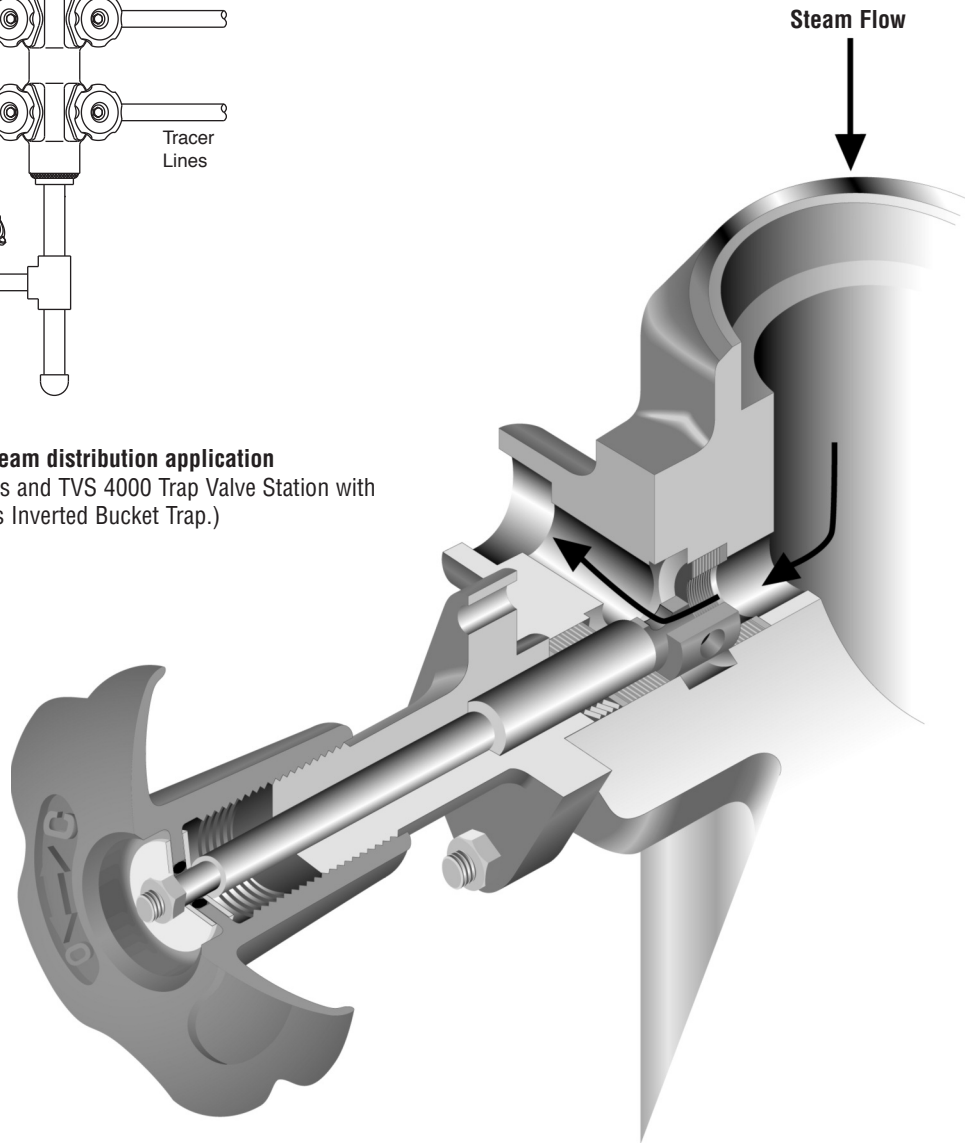

Steam Distribution Manifold (MSD/SMSD)

Model	MSD Series						SMSD Series					
	MSD-04		MSD-08		MSD-12		SMSD-04		SMSD-08		SMSD-12	
	in	mm	in	mm	in	mm	in	mm	in	mm	in	mm
"A" (Open Position)	8	203	8	203	8	203	8	203	8	203	8	203
"B" Height	11-1/2	292	24-1/4	615	37-1/8	243	10-1/4	260	19-3/4	501	29-1/4	743
"C" C to C	6-3/8	162	6-3/8	162	6-3/8	162	4-3/4	120	4-3/4	120	4-3/4	120
"D" Blowdown Connection	3/4 SW	20	3/4 SW	20	3/4 SW	20	3/4 SW	20	3/4 SW	20	3/4 SW	20
"E" Number of Holes for Mounting (M14)	2	2	4	4	6	6	2	2	4	4	6	6
"G" Inlet	1-1/2 SW	40	1-1/2 SW	40	1-1/2 SW	40	1-1/2 SW	40	1-1/2 SW	40	1-1/2 SW	40
"F" Outlet*	1/2	15	1/2	15	1/2	15	1/2	15	1/2	15	1/2	15
Weight, lb (kg)	21 (10)		46 (21)		67 (30)		20 (9)		40 (18)		59 (27)	
Maximum Operating Pressure	464 psi (32 bar) @ 752°F (400°C)											

*3/4" (20 mm) available – contact factory.

List of Materials	
Name	Material
Manifold Body	ASTM A105 forged steel
Handwheel	Ductile iron
Bonnet	ASTM A351 Gr. CF8M
Spring Washer	Stainless steel
Bonnet, Bolts	DIN 933, Gr. 8.8 per DIN 267
Piston & Stem	17% Chrome stainless steel
Valve Sealing Rings	Expanded graphite & stainless steel

For a fully detailed certified drawing, refer to CD #1097.

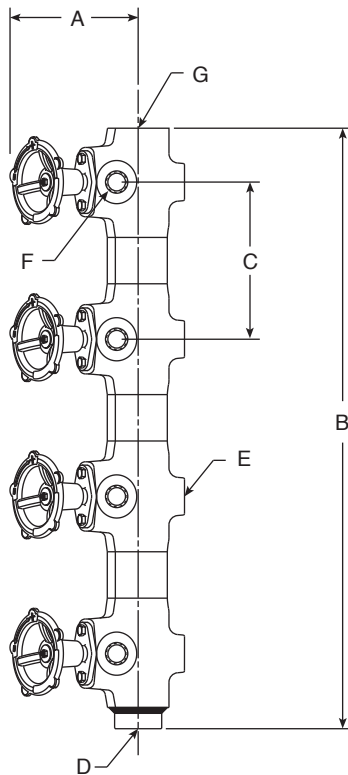

Steam Distribution Manifold



Steam Distribution Manifold
With TVS 4000, Inverted Bucket Drip Trap and Optional Stand

All dimensions and weights are approximate. Use certified print for exact dimensions. Design and materials are subject to change without notice.